

## 650V N-Channel Super-Junction MOSFET Gen-II

### Description

SJ-FET is new generation of high voltage MOSFET family that is utilizing an advanced charge balance mechanism for outstanding low on-resistance and lower gate charge performance.

This advanced technology has been tailored to minimize conduction loss, provide superior switching performance, and withstand extreme dv/dt rate and higher avalanche energy.

SJ-FET is suitable for various AC/DC power conversion in switching mode operation for higher efficiency.

### Features

- Multi-Epi process SJ-FET
- 700V @TJ = 150 °C
- Typ. RDS(on) = 1.05Ω
- Ultra Low Gate Charge (typ. Qg = 10.4nC)
- 100% avalanche tested

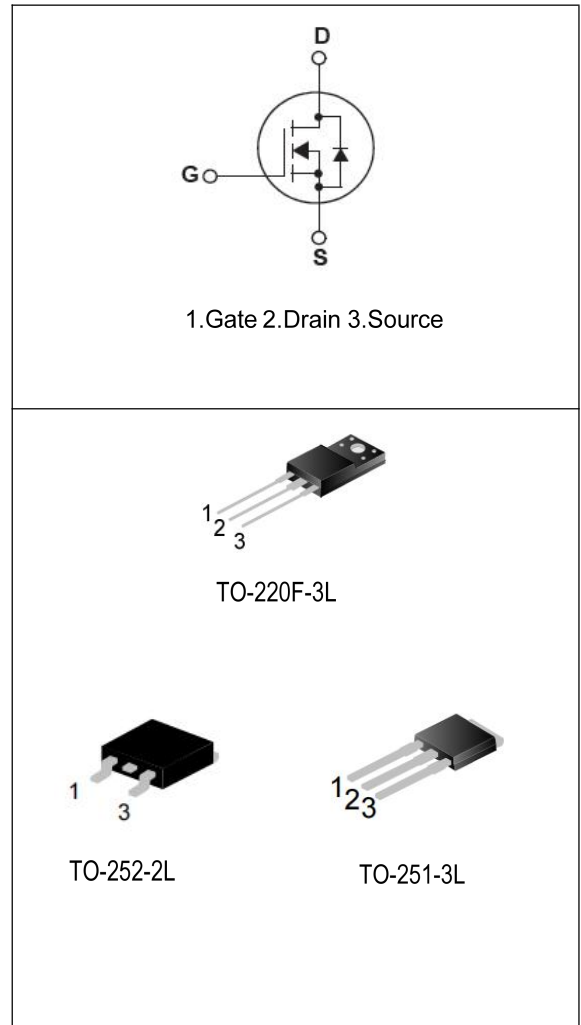

### Package Marking and Ordering Information:

Marking	Package	Part #	Hazardous Substance Control	Packing
SR65R1K2F	T0-220F-3L	SR65R1K2F	Pb free	Tube
SR65R1K2M	T0-251-3L	SR65R1K2M	Halogen free	Tube
SR65R1K2D	T0-252-2L	SR65R1K2D	Halogen free	Reel

**Absolute Maximum Ratings**

Symbol	Parameter	SR65R1K2D/M	SR65R1K2F	Unit
VDSS	Drain-Source Voltage	650		V
ID	Drain Current-Continuous(TC=25°C)	7.8*		A
	-Continuous(TC=100°C)	4.7*		
IDM	Drain Current-Pulsed(Note1)	18		A
VGSS	Gate-Source Voltage	±30		V
EAS	Single Pulsed Avalanche Energy(Note2)	24		mJ
IAS	Avalanche current,repitive or not-repitive (pulse width limited by Tj max)	1.2		A
DV/DT	Peak Diode Recovery DV/DT(Note3)	15		V/ns
DV/DS/DT	Drain Source Voltage Slope(Vds=480V)	50		V/ns
PD	Power Dissipation(TC=25°C)	43	30	W
TJ,TSTG	Operating and Storage Temperature Range	-55to+150		°C
TL	Maximun Lead Temperature for Soldring Purpose,1/16”from Case for 10 Seconds	260		°C

\* Drain current limited by maximum junction temperature . Maximum duty cycle D=0.75.

**Thermal Characteristics**

Symbol	Parameter	SR65R1K2D/M	SR65R1K2F	Unit
RθJC	Thermal Resistance,Junction-to-Case	3	4.2	°C/W
RθCS	Thermal Resistance,Case-to-Sink Typ	0.5	-	°C/W
RθJA	Thermal Resistance,Junction-to-Ambient	62	80	°C/W

**Electrical Characteristics TC = 25°C unless otherwise noted**

Symbol	Parameter	Conditions	Min	Typ	Max	Unit
<b>Off Characteristics</b>						
BVDSS	Drain-Source Breakdown Voltage	VGS=0V, ID=250uA Tj=25°C	650	-	-	V
		VGS=0V, ID=250uA Tj=150°C	-	700	-	V
BVDSS/TJ	Breakdown Voltage Temperature Coefficient	ID=250uA, Referenced to 25°C	-	0.6	-	V/°C
IDSS	Zero Gate Voltage Drain Current	VDS=650V, VGS=0V TC=125°C	-	-	1 100	uA uA
IGSSF	Gate-Body Leakage Current, Forward	VGS=30V, VDS=0V	-	-	100	nA
IGSSR	Gate-Body Leakage Current, Reverse	VGS=-30V, VDS=0V	-	-	-100	nA
<b>On Characteristics</b>						
VGS(th)	Gate Threshold Voltage	VDS=VGS, ID=250uA	2.0	3.0	4.0	V
Rg	Gate resistance	f=1MHz, open drain	-	10	-	Ω
RDS(on)	Static Drain-Source On-Resistance	VGS=10V, ID=2.3A	-	1.05	1.2	Ω
<b>Dynamic Characteristics</b>						
Ciss	Input Capacitance	VDS=200V, VGS=0V, f=1.0MHz	-	275	-	pF
Coss	Output Capacitance		-	9.5	-	pF
Crss	Reverse Transfer Capacitance		-	0.2	-	pF
<b>Switching Characteristics</b>						
td(on)	Turn-On Delay Time	VDS=400V, ID=1.3A RG=10Q, VGS=10V (Note4)	-	8.5	-	ns
tr	Turn-On Rise Time		-	12.5	-	ns
td(off)	Turn-Off Delay Time		-	22	-	ns
tf	Turn-Off Fall Time		-	16.5	-	ns
Qg	Total Gate Charge	VDS=400V, ID=4.5A VGS=10V, (Note4)	-	10.4	-	nc
Qgs	Gate-Source Charge		-	2.2	-	nc
Qgd	Gate-Drain Charge		-	5.1	-	nc
<b>Drain-Source Diode Characteristics and Maximum Ratings</b>						
IS	Maximum Continuous Drain-Source Diode Forward Current		-	-	4.5	A
ISM	Maximum Pulsed Drain-Source Diode Forward Current		-	-	18	A
VSD	Drain-Source Diode Forward voltage	VGS=0V, IS=4.5A	-	0.9	1.4	V
Trr	Reverse Recovery Time	VGS=0V, VDS=400V, IS=2.3A, dIF/dt=100A/us	-	170	-	ns
Qrr	Reverse Recovery Charge		-	0.75	-	uC
Irrm	Peak Reverse Recovery Current		-	8.5	-	A

**NOTES:**

- 1.Repetitive Rating:Pulse width limited by maximum junction temperature.
- 2.ID=IAS,VDD=50V,Starting TJ=25°C.
- 3.ISD≤ID,di/dt≤200A/us,VDD≤BVDSS,Starting TJ=25°C.
- 4.Essentially Independent of Operating Temperature Typical Characteristics.

**Typical Performance Characteristics**

 Safe operating area  $T_C=25^\circ\text{C}$ 

Non FullPAK

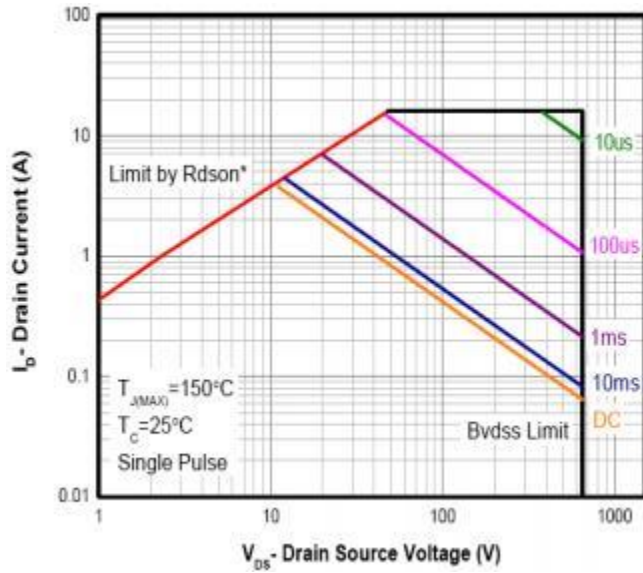
 Safe operating area  $T_C=25^\circ\text{C}$ 

TO-220FullPAK

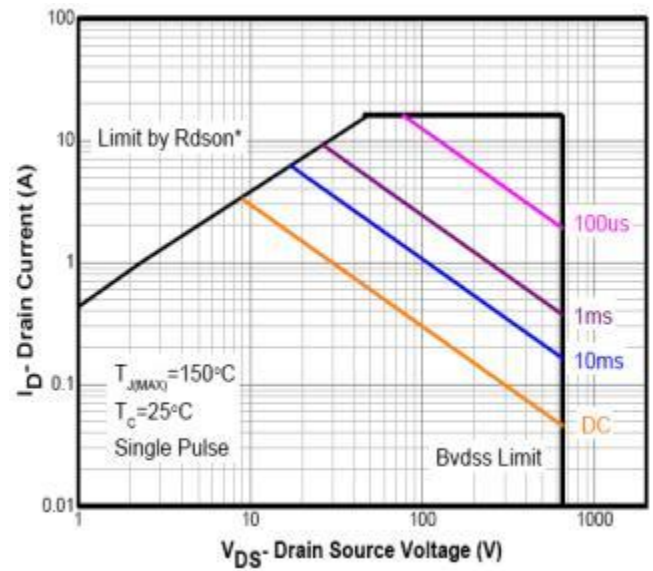
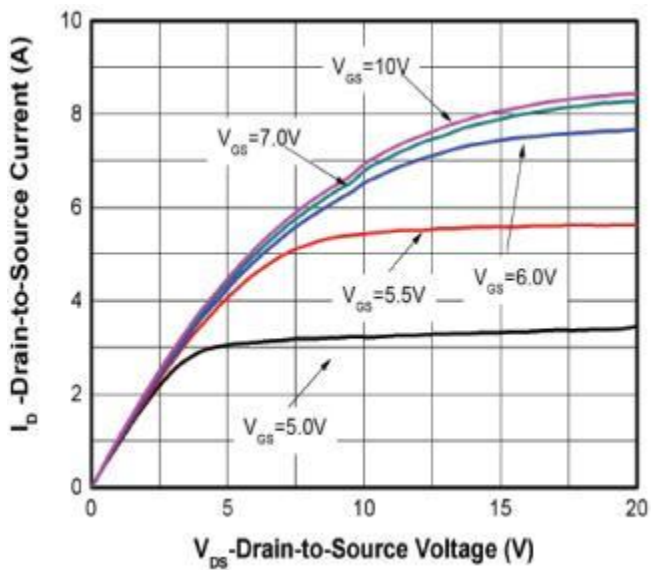

 Typ. output characteristics  $T_j=25^\circ\text{C}$ 

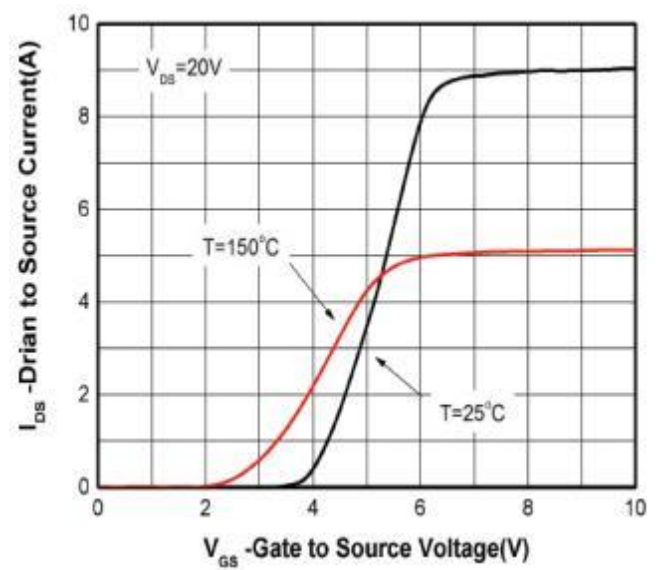
Typ. transfer characteristics

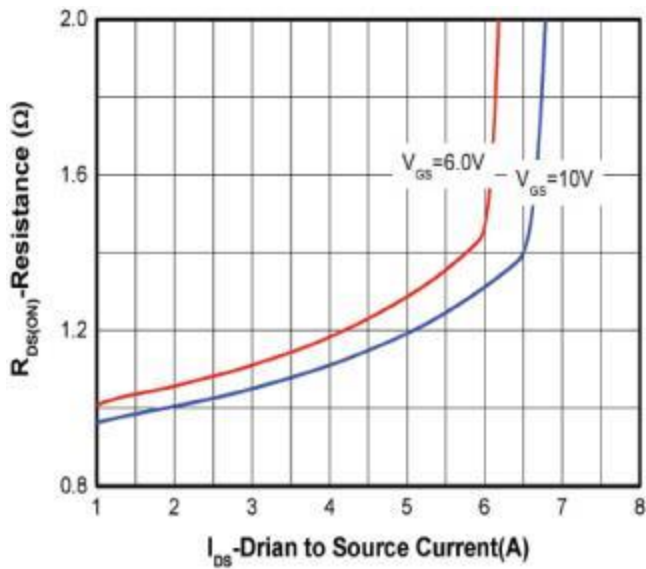

**Typical Performance Characteristics**

Typ. drain-source on-state resistance



Normalized on resistance vs temperature

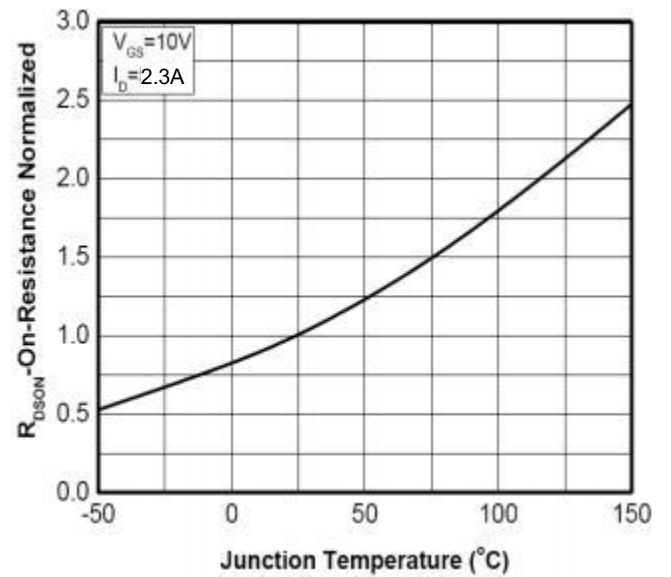

Typ. Capacitances

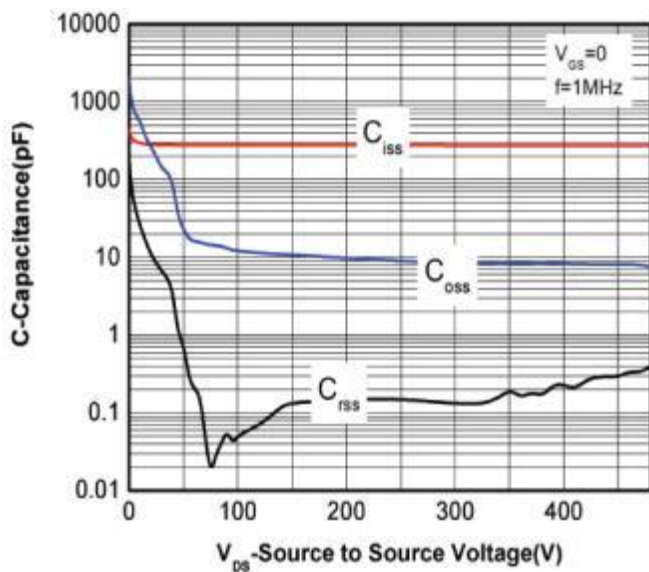

Typ. gate charge characteristics

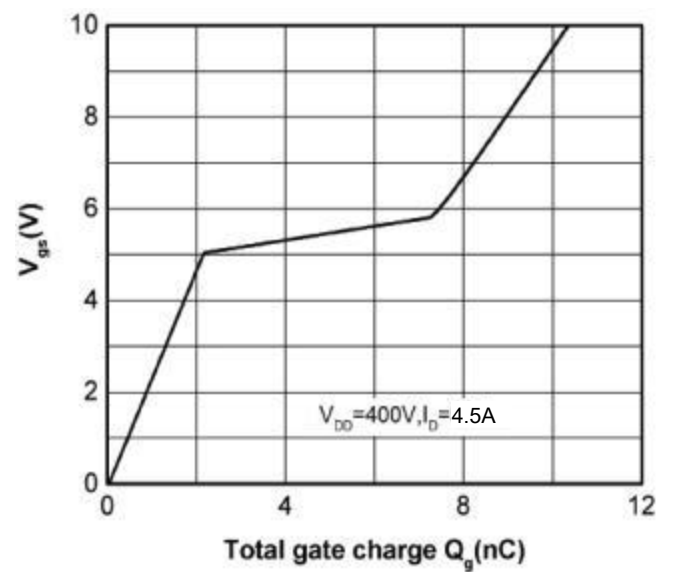



**Typical Performance Characteristics**

Power dissipation

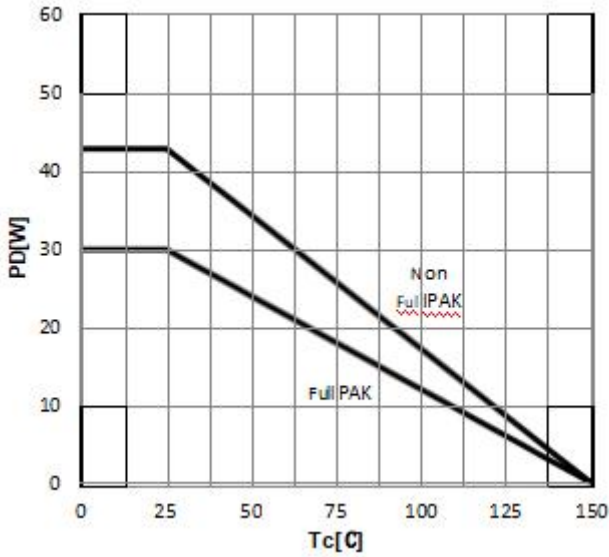

Forward characteristics of reverse diode

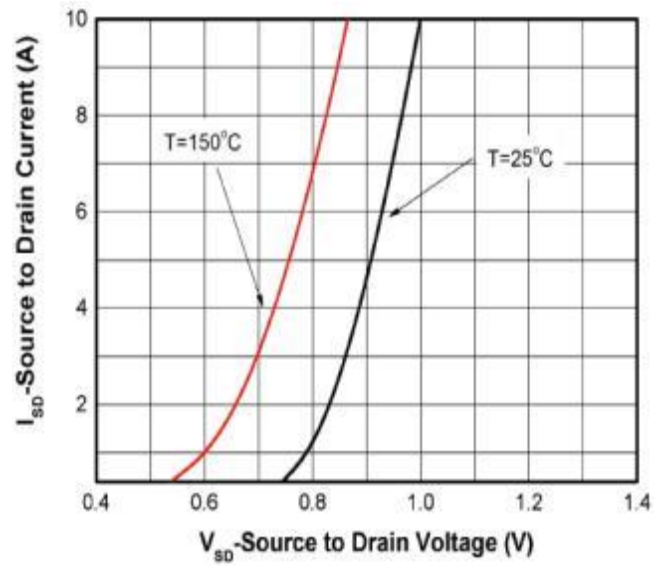

Drain-source breakdown voltage

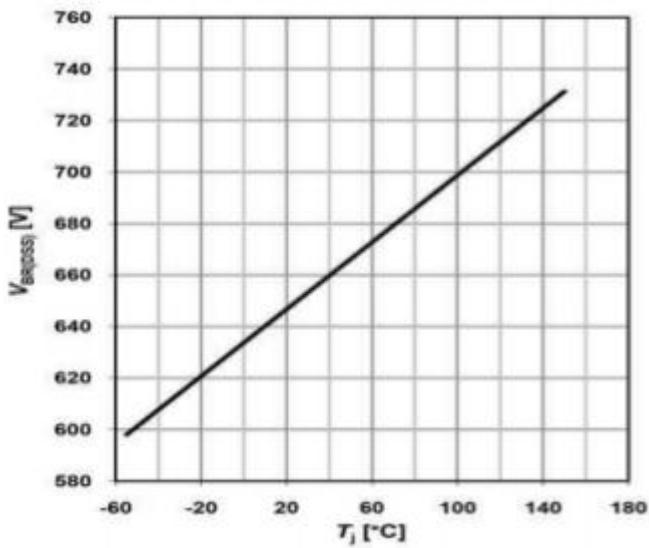

Normalized VGS(th) characteristics

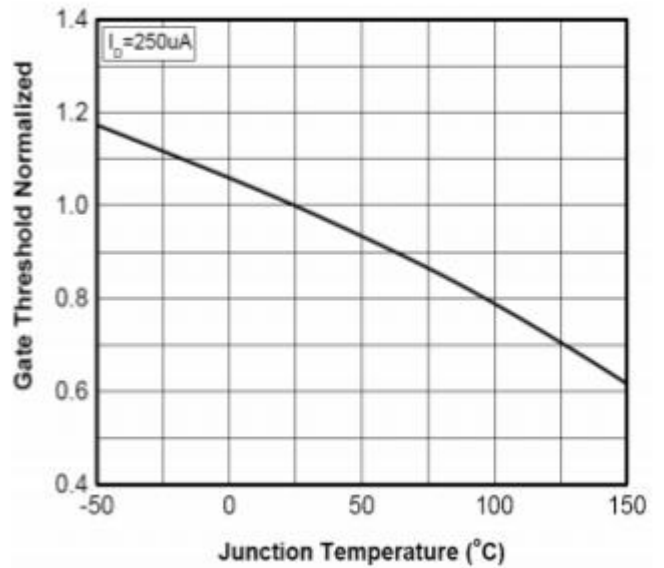

### Typical Performance Characteristics

Max. transient thermal impedance

Non FullPAK

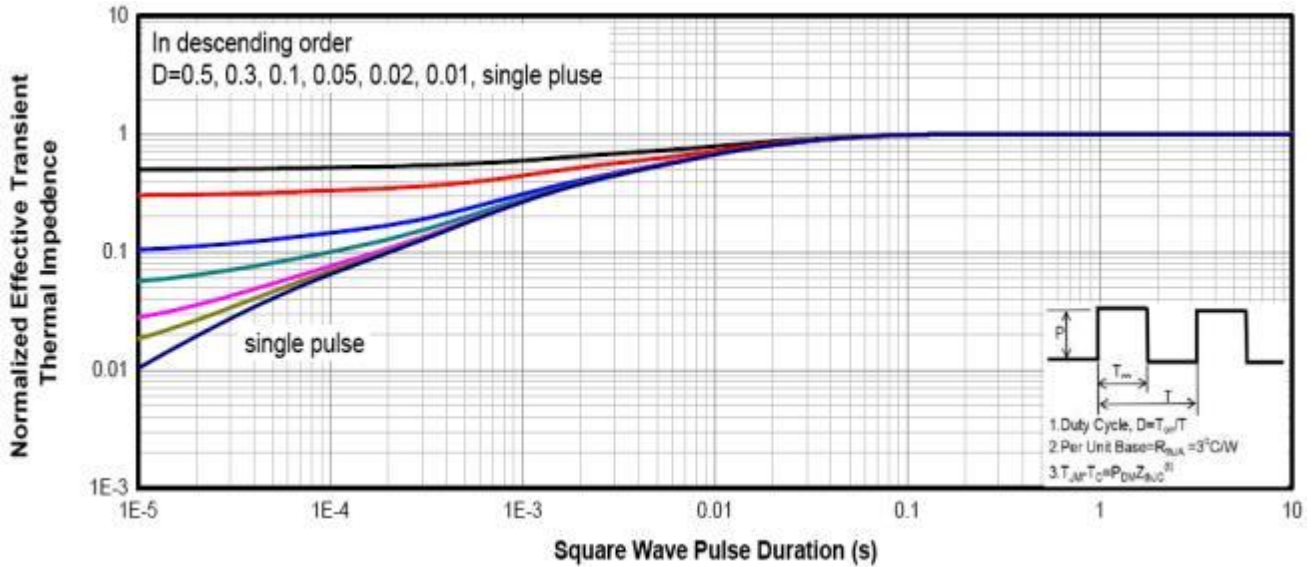

Max. transient thermal impedance

TO-220FullPAK

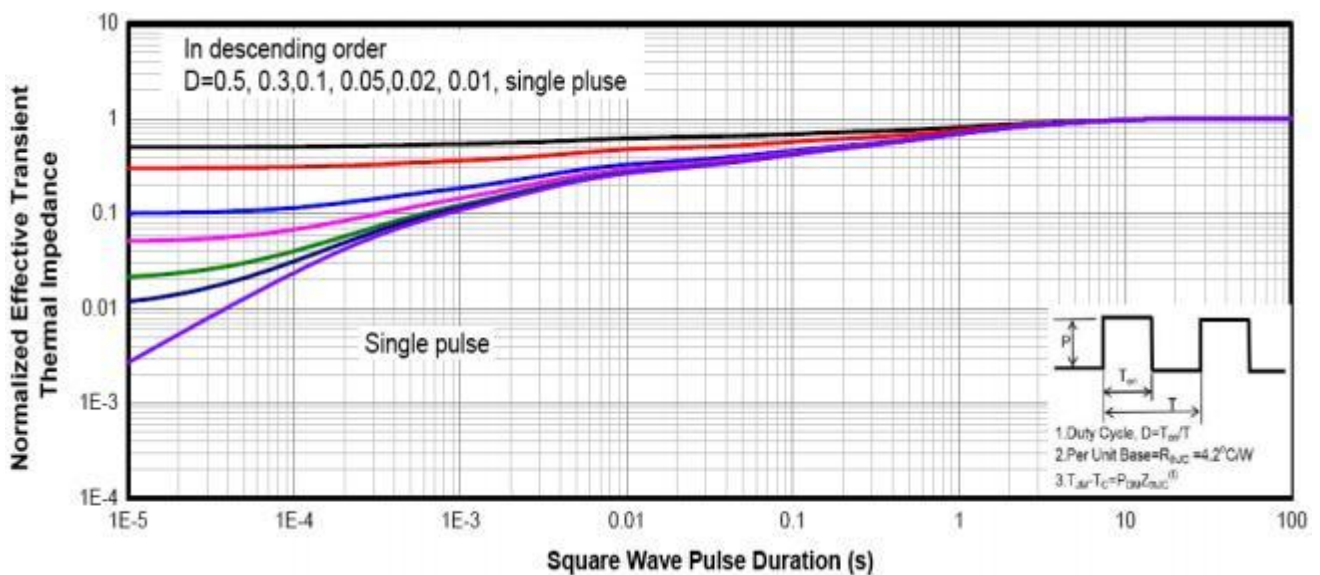



**Test circuits**

Switching times test circuit and waveform for inductive load

Switching times test circuit for inductive load

Switching time waveform

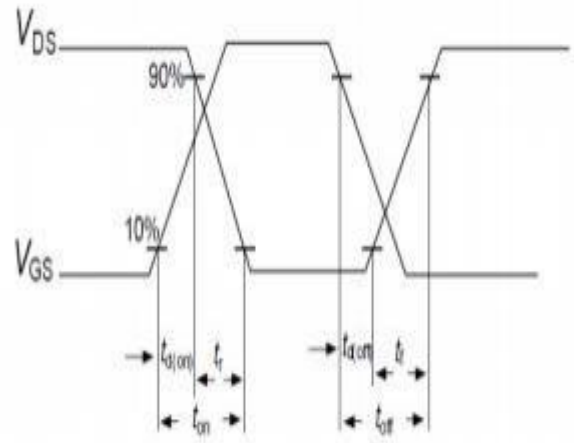
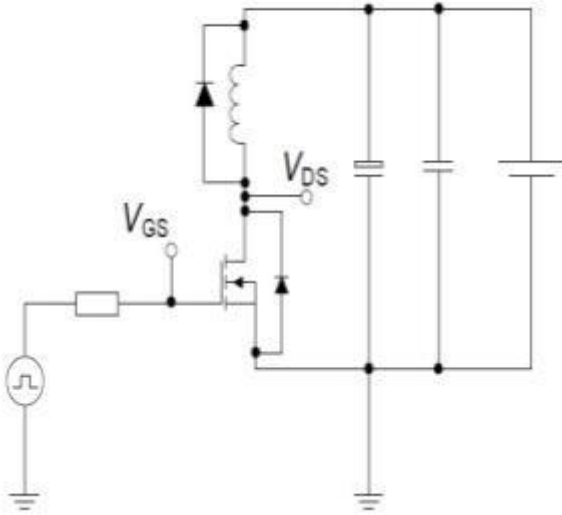

Unclamped inductive load test circuit waveform

Unclamped inductive load test circuit

Unclamped inductive waveform

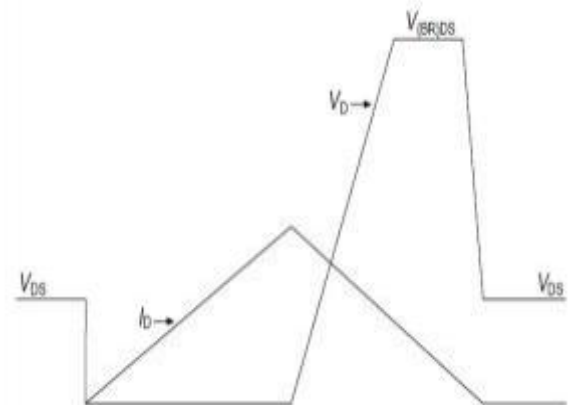
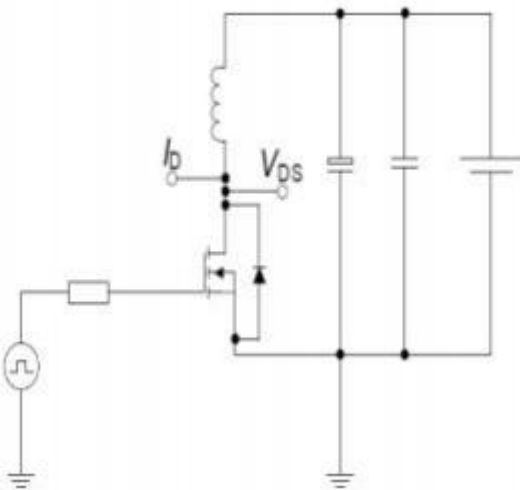

**Test circuits**

Test circuit and waveform for diode characteristics

Test circuit for diode characteristics

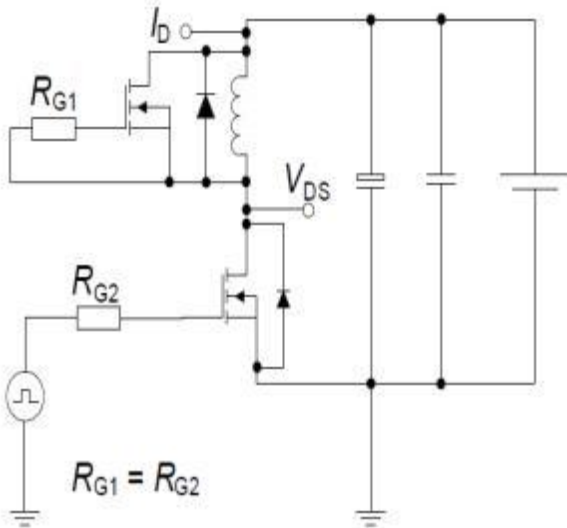

Diode recovery waveform

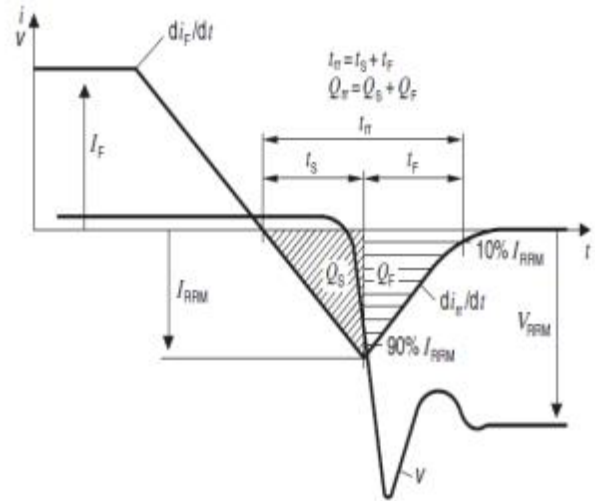

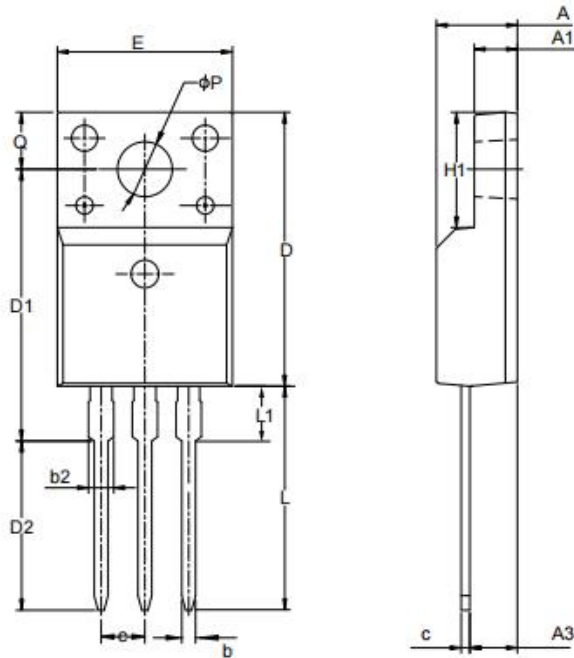
**Package Outline**
**TO-220 Full PAK**

COMMON DIMENSIONS			
Items	Values(mm)		
	MIN	NOM	MAX
A	4.42	4.7	5.02
A1	2.3	2.54	2.8
A3	2.5	2.76	3.1
b	0.7	0.8	0.9
b2	--	--	1.47
c	0.35	0.5	0.65
D	15.25	15.87	16.25
D1	15.3	15.75	16.3
D2	9.3	9.8	10.3
E	9.73	10.16	10.36
e	2.54BSC		
H1	6.4	6.68	7
L	12.48	12.98	13.48
L1	--	--	3.5
øP	3	3.18	3.4
Q	3.05	3.3	3.55

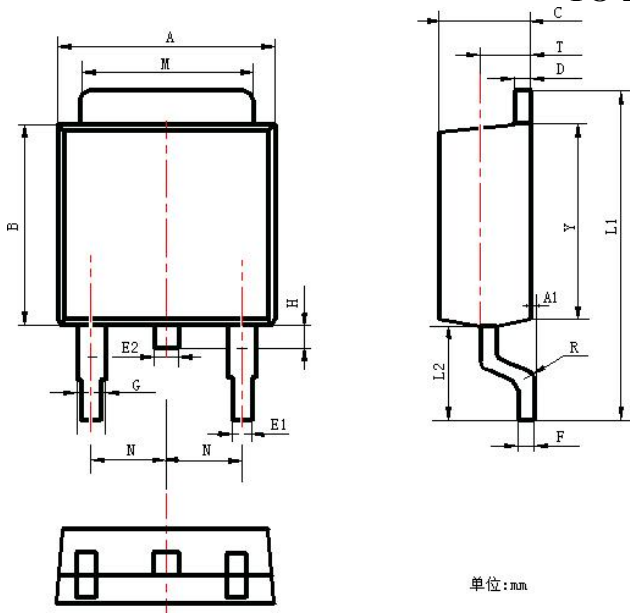
**TO-252-2L**

单位: mm

COMMON DIMENSIONS			
Items	Values(mm)		
	MIN	NOW	MAX
A	6.3	6.5	6.9
A1	0	-	0.16
B	5.7	-	6.3
C	2.1	2.3	2.5
D	0.3	0.5	0.7
E1	0.6	0.65	0.9
E2	0.7	0.65	1
F	0.3	0.5	0.6
G	0.7	0.9	1.2
L1	9.6	10	10.5
L2	2.7	-	3.1
H	0.4	-	1
M	5.1	5.2	5.5
N	2.09	2.2	2.49
R	0.3		
T	1.4	-	1.6
Y	5.1	5.9	6.3

**Package Outline**

TO-251-3L

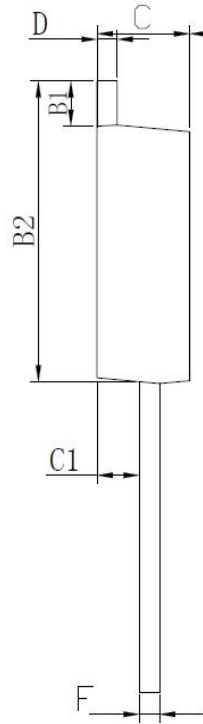
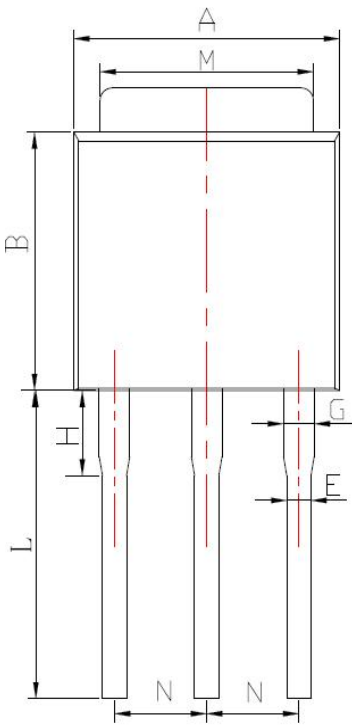

COMMON DIMENSIONS			
Items	Values(mm)		
	MIN	NOW	MAX
A	6.3	6.5	6.9
B	5	5.2	6.3
B1	0.7	1.1	1.3
B2	6.8	7.2	7.4
C	2.1	2.3	2.5
C1	0.9	-	1.2
D	0.3	0.5	0.6
E	0.5	0.65	0.86
F	0.3	0.5	0.6
G	0.7	-	1
H	1.4	2	2.4
L	9	9.4	9.8
M	5.1	5.2	5.5
N	2.09	2.2	2.49